



E³

PROPELLER EVOLUTION

INSTRUCTION BOOKLET



E⁴

PROPELLER EVOLUTION

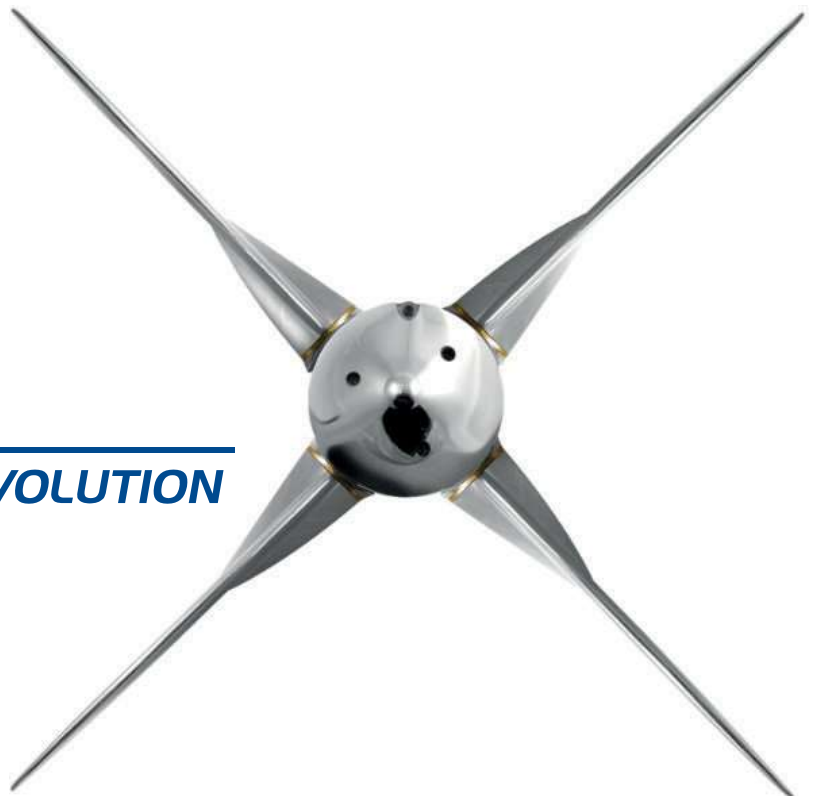



The EWOL E3 and E4 propellers are designed to be easily installed, adjusted and removed from the propeller shaft. These operations can be carried out both in or out of the water in just a few minutes, without the need to use a puller.

Carefully follow the standard assembly, disassembly and maintenance instructions given below.

Note: This booklet shows the layout of the three-blade propeller, but indiscriminately refers also to all 3- and 4-blade versions.

TABLE OF CONTENTS

Propeller assembly	Page 3
<ul style="list-style-type: none"> • Assembly for Sail-Drive versions 	Page 3
<ul style="list-style-type: none"> • Assembly for Shaft-Drive versions 	Page 4
Tightening torques	Page 5
Installation of the galvanic anode	Page 6
Adjustment of propeller pitch	Page 6
<ul style="list-style-type: none"> • Pitch adjustment procedure 	Page 7
Propeller operation	Page 8
Feathering position	Page 8
Propeller extraction	Page 9
Cathodic protection	Page 10
Rope cutter installation (optional)	Page 10
Application of antifouling paint	Page 11
Lubrication	Page 11
Maintenance	Page 11
Warnings	Page 12

PROPELLER ASSEMBLY

Ensure that the propeller shaft cannot rotate by engaging the gear when the engine is switched off or by locking the shaft.

ASSEMBLY FOR SAIL-DRIVE VERSIONS

- If you have a rope cutter for Sail-Drive versions, please refer to the assembly instructions on page 10.
- If the Sail-Drive leg is supplied by the manufacturer with a ring spacer for the propeller, leave it installed.
- Before engaging the propeller on the Sail-Drive shaft, we recommend a careful cleaning of the thread of the shaft, check in order to verify that there are no damages on the same together with its generous greasing.
- Engage the complete propeller assembly onto the shaft of the Sail-Drive leg (**Fig. 1 and 2**) and hold it in place before fixing.
- To avoid bending the propeller blades when turning, make sure you turn the blades in the thrust position (not in the feathering position), and lock the rotation with a wooden wedge, to be placed between the blade and the hull. (**Fig. 3**).
- Tighten the lock nut **A** (**Fig. 4**) applying an appropriate tightening torque (depending on the type of nut, such as suggested in the TABLE OF TIGHTENING TORQUES). When tightening, take care to move the blades and gradually tighten the nut until the specified tightening torque is reached.
- The propeller must fit completely onto the shaft of the Sail-Drive leg.
- A safety bolt **B** with special anti-unscrewing washer is provided, it must be screwed in after tightening the nut **A** (**Fig. 5**). If the installation is carried out of the water, you can apply medium strength threadlocker (e.g. Loctite® 243) to the thread of the shaft; if the operation is carried out in the water you can skip this operation because the lock nut **A** is however equipped with self-braking systems.
- If you have locked the propeller shaft with a wedge or other device, remember to unlock it before restarting the engine.

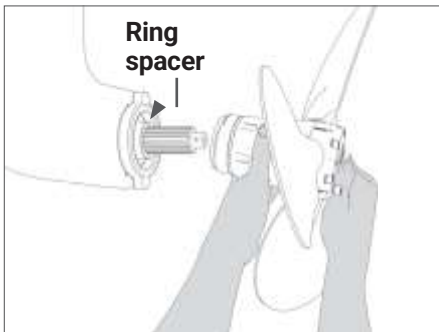

FIG. 1 How to insert the propeller on the Sail-Drive shaft

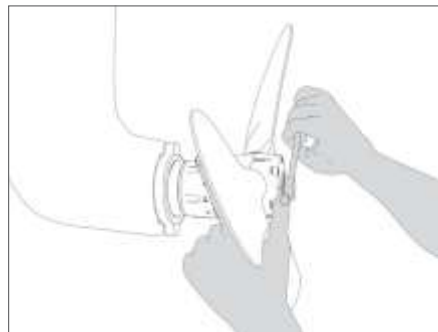

FIG. 2 Hold the propeller on the shaft before fixing it



FIG. 3 Rotation locking

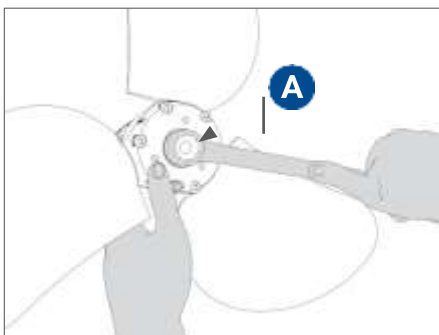

FIG. 4 Lock nut tightening

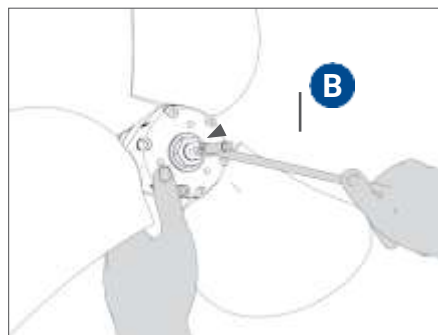

FIG. 5 Safety bolt (Sail-Drive) tightening

ASSEMBLY FOR SHAFT-DRIVE VERSIONS

If the installation is performed out of the water, a pre-assembly check can be carried out.

PRE-ASSEMBLY CHECK

- In order to check that the key is not too high so as to push the propeller off-centre, run an initial assembly test without the key:
 - Before engaging the propeller on the shaft, we recommend a careful cleaning of the thread of the shaft, check in order to verify that there are no damages on the same together with its generous greasing.
 - Engage the propeller assembly onto the shaft without a key (**Fig. 6 and 7**), hold it in place and tighten the nut **A** until the end (**Fig. 8**).
 - Use a felt-tip pen to mark the maximum fitting point on the shaft (**Fig. 9**).
- Unscrew the lock nut **A** (**Fig. 10**) and take off the propeller (**Fig. 11**).

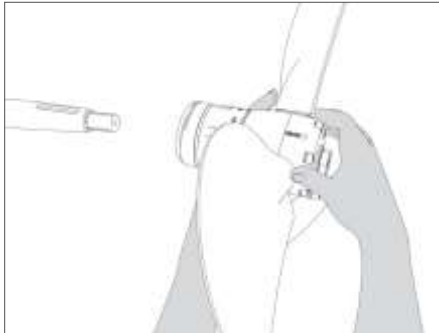

FIG. 6 Propeller insertion onto the shaft

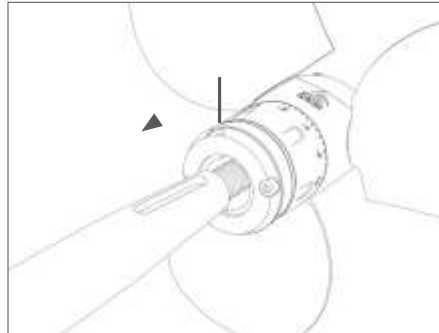

FIG. 7 Inserting the propeller on the shaft without a key

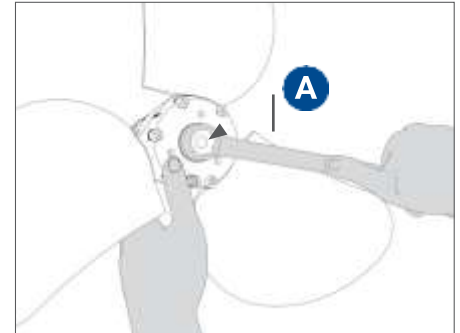

FIG. 8 Lock nut tightening

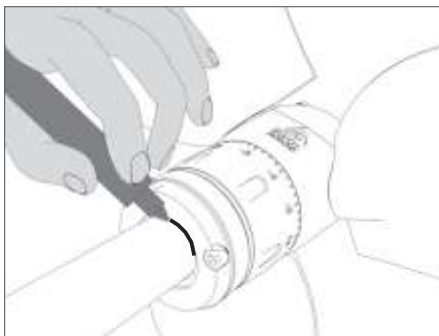

FIG. 9 Mark with a felt-tip pen here on the shaft

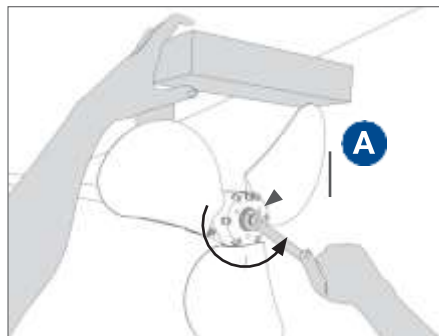

FIG. 10 Unscrew the lock nut

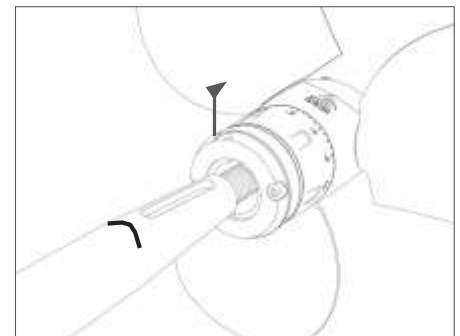

FIG. 11 Take off the propeller from the shaft

FINAL ASSEMBLY

- Insert the key on the shaft (**Fig. 12**).
- Engage the complete propeller set onto the propeller shaft (**Fig. 13**) and hold it in place before fixing.
- To avoid bending the propeller blades when turning, make sure you turn the blades in the thrust position (not in the feathering position), and lock the rotation with a wooden wedge, to be placed between the blade and the hull. (**Fig. 14**).
- Tighten the lock nut **A** (**Fig. 14**) applying an appropriate tightening torque (depending on the type of nut, as recommended in the TABLE OF TIGHTENING TORQUES). When tightening, take care to move the blades and gradually tighten the nut until the specified tightening torque is reached.

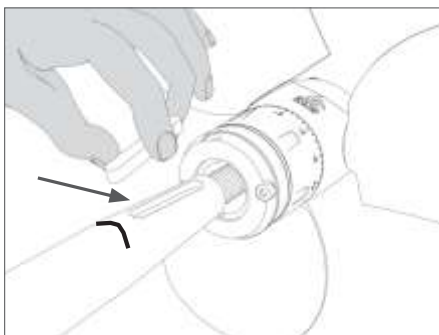

FIG. 12 Inserting the key on the shaft

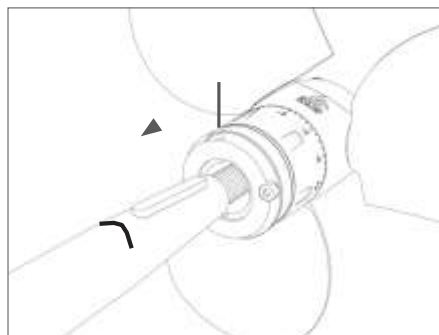

FIG. 13 Engaging the propeller on the shaft with the key

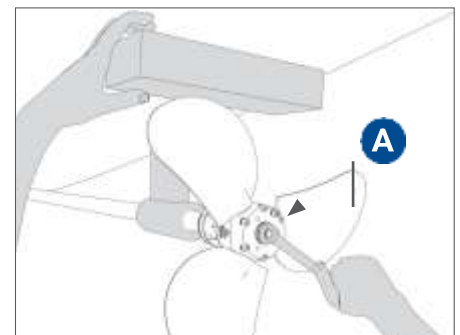

FIG. 14 Lock rotation and tighten the lock nut

- The propeller must be fitted onto the cone of the propeller shaft until it reaches the mark made before key insertion (**Fig. 15**); failing this indicates that the key is too high and prevents the propeller from fitting completely. In this case you will have to reduce the thickness of the key and then reinstall the propeller.
- For the shaft-drive versions, the safety bolt **B** is included in the supply and the tightening nut **A** is specifically designed for the use of safety bolt, upon customer's choice.
If you choose this solution for greater safety, you will have to drill a threaded hole in the propeller shaft with a thread size suitable for the bolt, making sure that it is centred and perfectly aligned (**Fig. 16**), to be able to insert the safety **B** bolt (**Fig. 17**).
- If the installation is carried out of water, you can apply medium strength threadlocker (e.g. Loctite® 243) to the thread of the shaft; if the operation is carried out in the water you can skip this operation because the lock nut **A** is however equipped with self-braking systems.
- If you have locked the propeller shaft with a wedge or other device, remember to unlock it before restarting the engine.

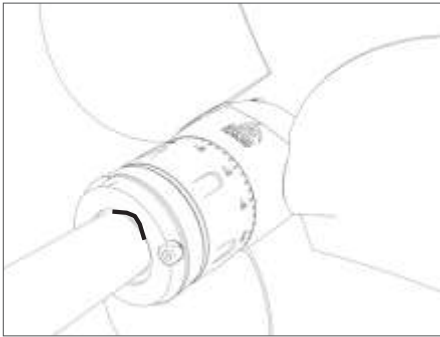

FIG. 15 Insert the propeller up to the mark made with the felt-tip

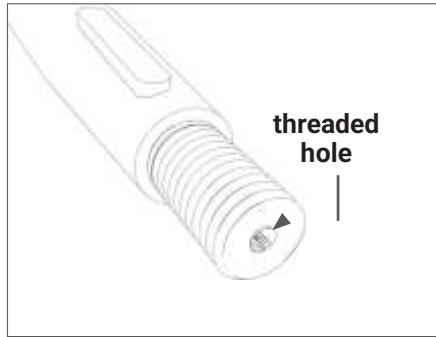

FIG. 16 Drill the threaded hole on the shaft; it should be perfectly centred and aligned

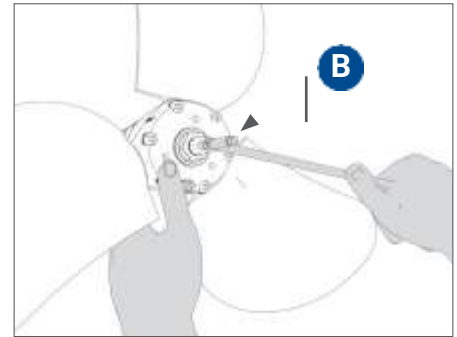

FIG. 17 Safety bolt tightening

TIGHTENING TORQUES

Stainless steel shafts AISI316 - A4-70 - WITH lubrication / AVEC lubrifiant / CON lubrificazione - coefficient 0.13 (it is always recommended to apply an anti-seizing grease on stainless steel threads)				
Shaft / S-Drive	Nut (A) Metric		Locking bolt (B)	
	Thread	Torque (Nm)	Thread	Torque (Nm)
Sail-Drive SD20 - Volvo S-Drive	M16x2	70	M8x1.25	15
Sail-Drive SD40-SD50-SD60-SD15	M20x2	100	M8x1.25	15
ISO 22	M16x1,5	138	M8x1.25	16
ISO 25	M16x1,5	138	M8x1.25	16
ISO 30	M20x1,5	269	M8x1.25	16
ISO 35	M24x2	470	M8x1.25	16
ISO 40 prop model ORION (GEMINI)	M24x2	470	M8x1.25 (M10x1.25)	16 (30)
ISO 45 prop model GEMINI (PEGASUS)	M30x2	930	M10x1.25 (M12x1.75)	30 (53)
ISO 50 prop model GEMINI (PEGASUS)	M36x3	1613	M10x1.25 (M12x1.75)	30 (53)
ISO 55	M36x3	1613	M12x1.75	53
3/4" SAE	UNC 1/2" - 13	72,3	M8x1.25	16
1" SAE	UNC 3/4" - 10	198	M8x1.25	16
1-1/8" SAE	UNC 3/4" - 10	198	M8x1.25	16
1-1/4" SAE	UNC 7/8" - 9	318	M8x1.25	16
1-3/8" SAE	UNC 1" - 8	484	M8x1.25	16
1-1/2" SAE prop model ORION (GEMINI)	UNC 1-1/8" - 7	553	M8x1.25 (M10x1.25)	16 (30)
1-3/4" SAE prop model GEMINI (PEGASUS)	UNC 1-1/4" - 7	770	M10x1.25 (M12x1.75)	30 (53)
2" SAE	UNC 1-1/2" - 6	996	M12x1.75	53

INSTALLATION OF THE GALVANIC ANODE

- Engage the anode **C** and secure it with 3 stainless steel screws **D** (Fig. 18 - 19 - 20).
- **Important:** if installation is carried out of the water, apply medium strength threadlocker (e.g. Loctite® 243) to the thread of the screws.

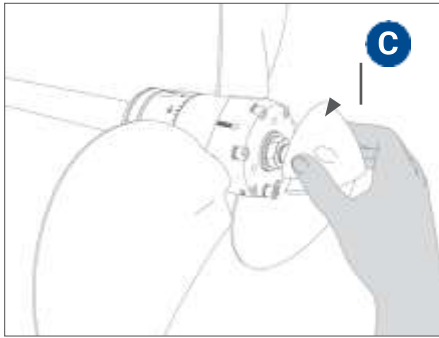

FIG. 18 Engage anode "C"

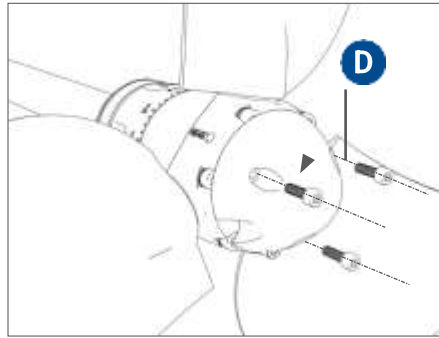

FIG. 19 Engage anode "D" screws

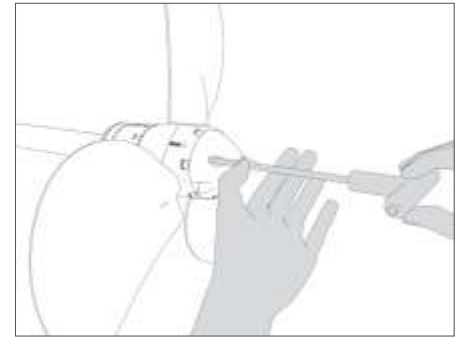

FIG. 20 Anode fixing with screws

ADJUSTMENT OF PROPELLER PITCH

The pitch of the EWOL propeller is directly proportional to the incidence angle of the blades. All EWOL propellers setpoints are carefully calculated according to the data provided by the customer.

The propeller setpoint values are set at the factory at the middle of the setting range, unless specifically agreed with the customer. Therefore, the dot symbol "○" on the ring nut and the other dot symbol "○" on the body will be aligned (Fig. 21).

Once you have installed the propeller and the first propulsion test has been carried out, you can change the pitch at will to optimise the boat's propulsion performance.

In order to determine the correct pitch, EWOL recommends that you refer to the engine manufacturer's instructions to find out the maximum rpm that the engine should take at full throttle.

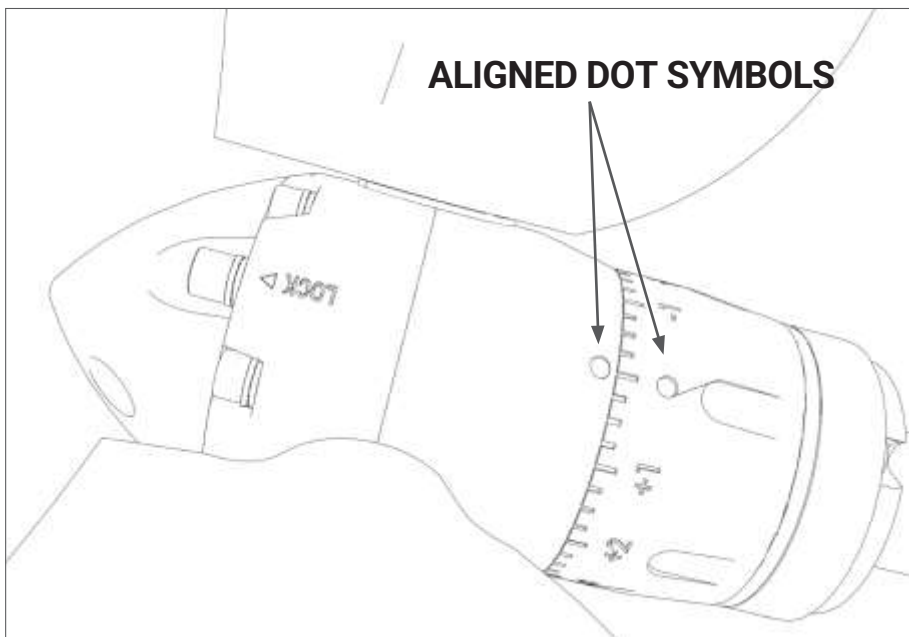

FIG. 21 Factory default setting

PITCH ADJUSTMENT PROCEDURE:

- Bring the blades to the feathering position (Fig. 22 - 23).
- Unscrew the set screw (indicated with **F** in Fig. 24) by 5-6 turns; this will allow you to adjust the pitch without the risk of losing the screw in the water (important: at 10 turns, the screw comes completely out from the propeller with the risk of losing it).
- To adjust the pitch at the desired value, turn the ring nut while precisely aligning the selected notch with the symbol "O" on the propeller body (Fig. 25).
- Each adjustment notch corresponds to a change in blade angle of 0.25° and causes an increase or decrease of approximately 40-50 rpm of the engine at the same boat speed (this value is purely indicative and depends on the specifications of the engine installed). The standard adjustment range is from a minimum of 14° to a maximum of 26° (Fig. 26). Pitch adjustment within a range from a minimum of 20° to a maximum of 32° can be also available for special applications.
- Tighten the set screw **F** (Fig. 27) making sure that the screw fits properly and easily into its housing (If you find it difficult to tighten the screw, use the ring nut and tighten the screw slowly until it fits correctly into its slot). The locking screw is equipped with a wedge-locking washer in two halves, be careful not to lose it, it is also recommended not to tighten the set screw too hard, max 7 Nm (0,7 Kgm).

Thanks to the micrometric pitch adjustment system (MPS), the EWOL propeller allows optimising engine speed, fuel consumption and boat speed.

Appropriate pitch adjustments allow the motor to reach the maximum speed stated by the manufacturer. If the actual speed differs from the maximum speed stated by the manufacturer, the blade angle must be adjusted. An incorrect inclination to the angle of the blades results in an inappropriate pitch, which can lead to excessive fuel consumption, overheating or insufficient speed.

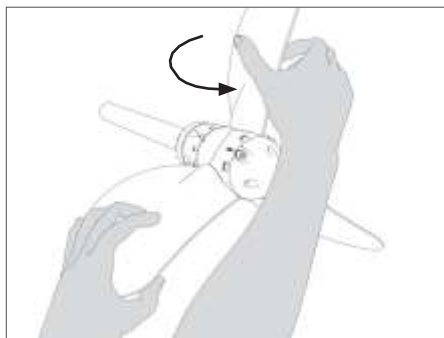

FIG. 22 Bring the blades to the feathering position

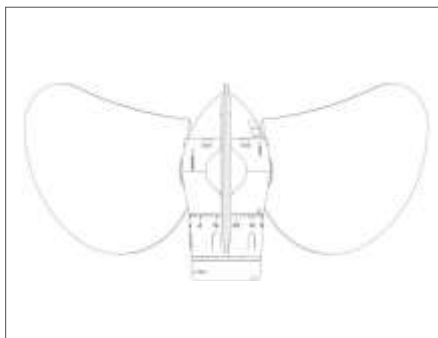

FIG. 23 Blades in the feathering position

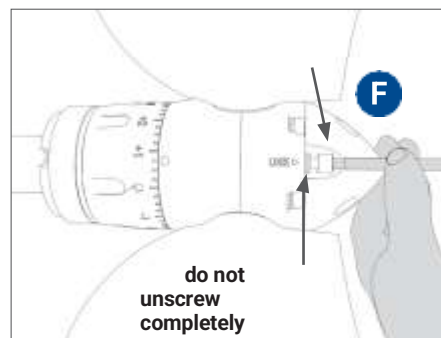

FIG. 24 Loosening of the set screw

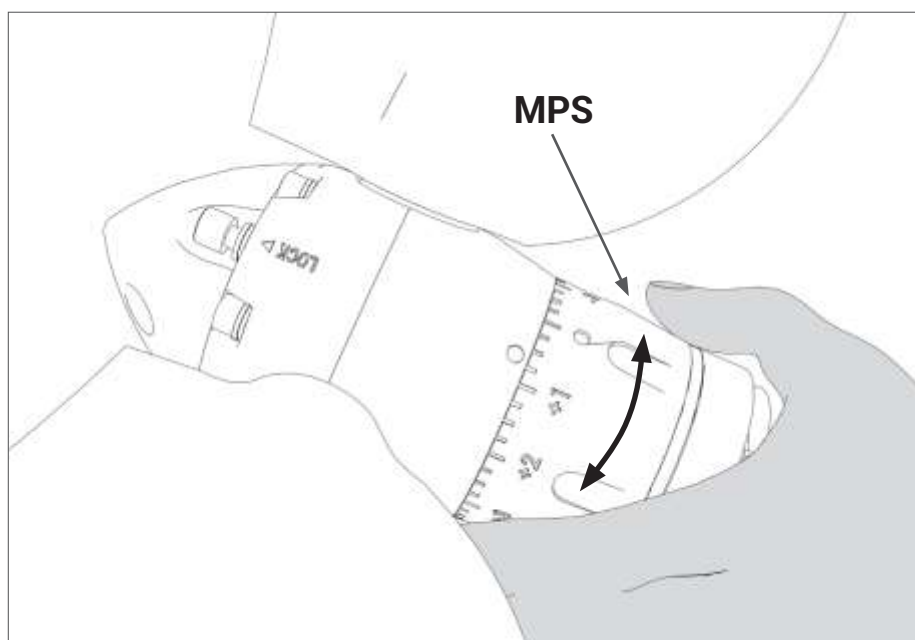

FIG. 25 Pitch adjustment

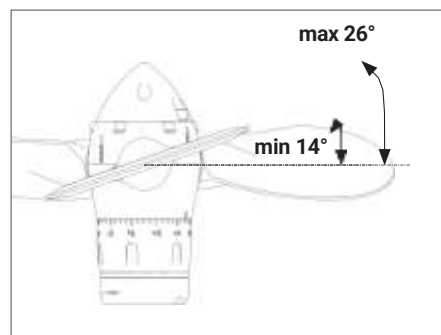

FIG. 26 Standard setting range

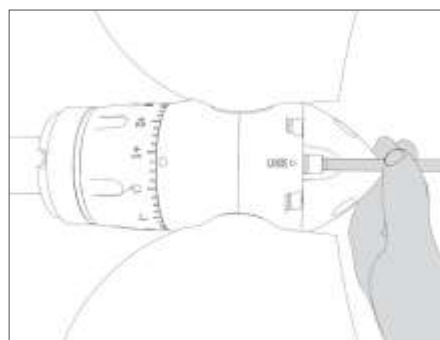

FIG. 27 Tighten the set screw

PROPELLER OPERATION

Once the pitch has been set, the EWOL propeller works fully automatically: the blades move forward according to the pitch and the set angle and at a fixed angle pitch in reverse gear.

Moving in reverse gear at high engine speeds should be avoided in order to prevent damaging internal components and the inverter.

FEATHERING POSITION

MECHANICAL GEARBOX

In order to set the propeller in the feathering position, it is necessary to lock the rotation of the shaft during the cruise. Normally, the following procedure is sufficient:

- Drive the boat at least 3-4 knots forward.
- Switch off the engine without disengaging the gear or, if the engine has already been switched off, engage the forward gear.
- The blades will now automatically move to feathering position, with minimum resistance to movement (**Fig. 28**).
- If the propeller does not move to feathering position using the above procedure, leave the engine off and engage the reverse gear.

HYDRAULIC GEARBOX

- If the gearbox is not mechanical but hydraulic, at a speed of at least 3-4 knots, reduce the engine speed to minimum rpm and switch off the engine with the forward gear engaged so that the pressurised oil in the circuit can lock the shaft even for just 1 second.
- If the above procedure is not sufficient, it will then be necessary to give a short burst of reverse propulsion with the engine running (while sailing at minimum 3-4 knots) and then turn the engine off. If this procedure does not work, it is necessary to install a device to brake the propeller shaft (e.g. a shaft brake).

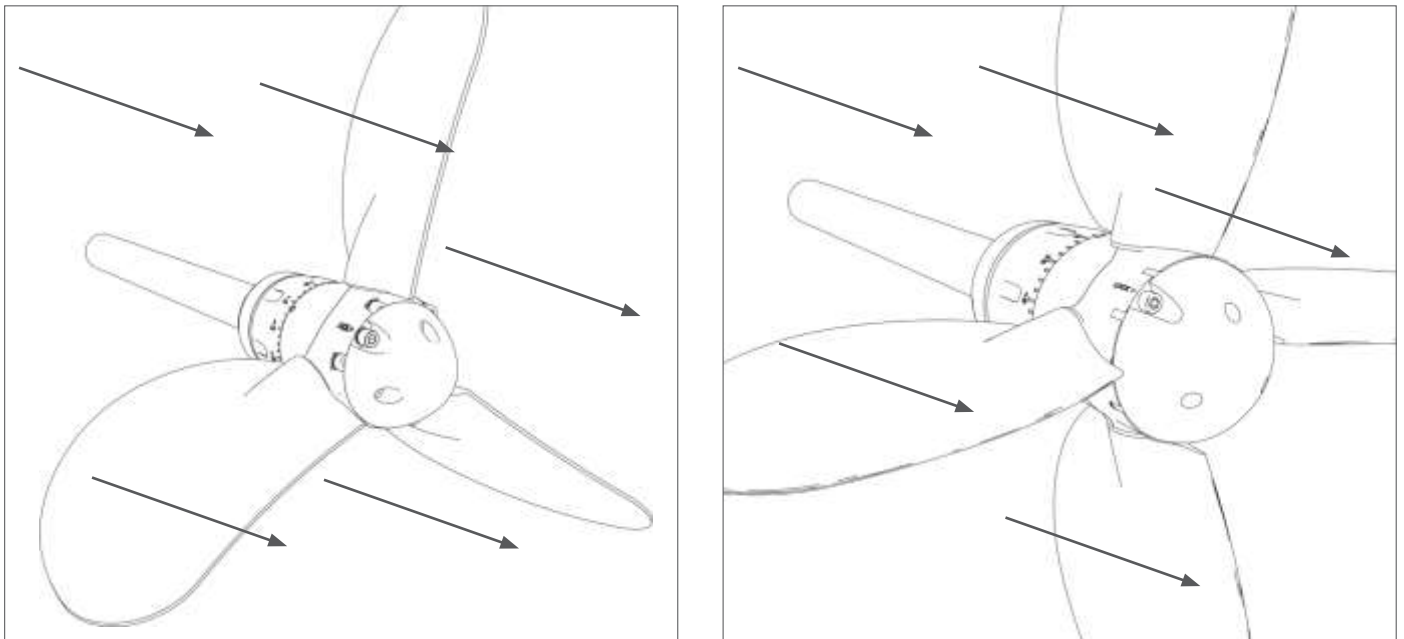

FIG. 28 Water flow

PROPELLER EXTRACTION

Removing the propeller set from the propeller shaft can be done quickly without the use of pullers. Proceed as follows:

IMPORTANT!

DO NOT DISASSEMBLE THE PROPELLER FOR ANY REASON, HENCE NEVER LOOSEN THE "H" SCREW (Fig. 29) AND NEVER UNSCREW THE PROPELLER HEAD SCREWS MARKED WITH THE LETTER "T" (Fig. 30).

SHOULD IT BE NECESSARY TO DISASSEMBLE THE PROPELLER BODY, CONSULT THE EWOL SERVICE BEFORE PROCEEDING.

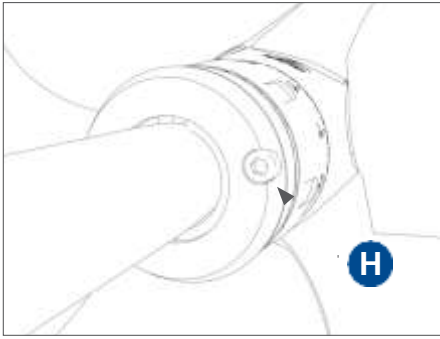

FIG. 29 Spring clamp screw "H"

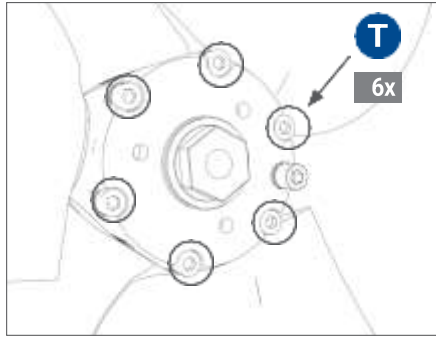

FIG. 30 Propeller head screws "T"

- Remove the tip **C** unscrewing the stainless steel screws **D** (Fig. 31 - 32 - 33).
- Ensure that the propeller shaft cannot rotate by engaging the gear when the engine is switched off or by locking the shaft. To avoid bending the propeller blades during unscrewing, make sure you turn the blades in the thrust position (not in the feathering position), and lock the rotation with a wooden wedge, to be placed between the blade and the hull. (Fig. 35).
- Loosen the safety bolt **B** (if it was installed) counterclockwise (Fig. 34).
- Unscrew the lock nut **A** counterclockwise (Fig. 35); during unscrewing, the propeller will automatically come out from the cone of the propeller shaft or the Sail-Drive shaft.

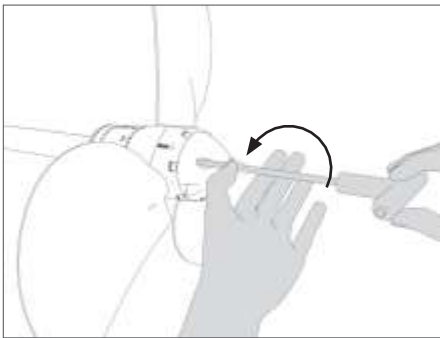

FIG. 31 Unscrewing the tip screws

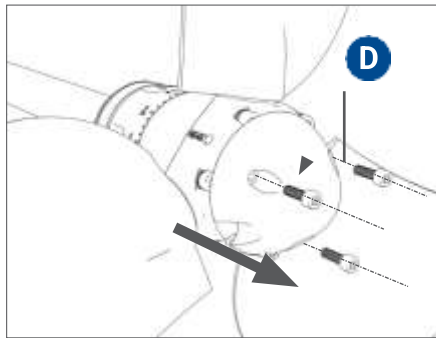

FIG. 32 Screw extraction tip "D"

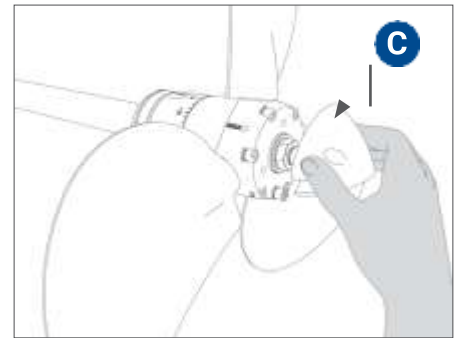

FIG. 33 Removing the "C" tip

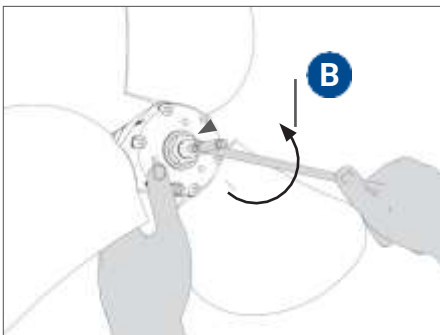

FIG. 34 Unscrew safety bolt "B"

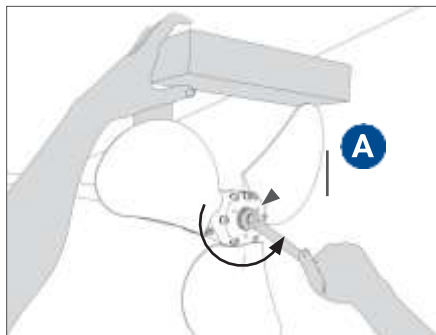

FIG. 35 Unscrew lock nut "A"

CATHODIC PROTECTION

The EWOL propeller is made entirely of special stainless steel and, therefore, it is highly resistant to galvanic corrosion. However, the propeller is equipped with a galvanic anode (zinc or aluminium tip) as standard component that must be replaced regularly in accordance with its wear condition (normally to be checked at the end of each season).

The use of original EWOL galvanic anodes is recommended (**Fig. 36**), these can be ordered on www.ewoltech.com or www.ewol-propellers.com (from the USA).

In addition to the standard galvanic anode, it is recommended that a collar anode be installed on the propeller shaft or Sail-Drive leg anode to provide additional protection against corrosion processes that involve other boat components (**Fig. 37**).



FIG. 36 Original EWOL galvanic anode

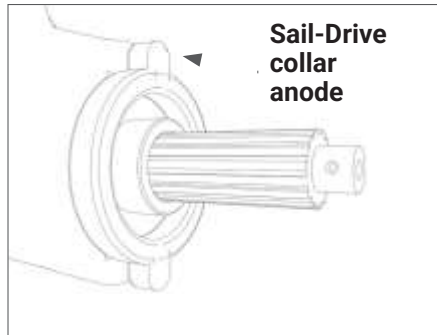

FIG. 37 Sail-Drive collar anode

INSTALLATION OF ROPE CUTTER (OPTIONAL)

The EWOL rope cutter is a blade disc made of Superduplex stainless steel with a central coupling compatible with the back of the propeller (**Fig. 38**). This design is extremely simple and sturdy and, due to its shape, allows for further sharpening without having to resharpen it at the factory.

When installing the rope cutter, use gloves or handle with utmost care to avoid accidental injury.

Engage the central hole of the special-profile rope cutter with the four stems (**Fig. 40**) in the corresponding male part on the end of the propeller, where the grooved thread for mounting on the Sail-Drive shaft is placed (**Fig. 39**).

Now fit the propeller onto the Sail-Drive shaft and fasten it as described on page 3 "Assembly for Sail-Drive versions". The rope cutter will be pressed between the propeller and the metal end stop of the Sail-Drive shaft (**Fig. 41**).

It should be noted that this type of rope cutter is specifically designed for the Sail-Drive version and cannot be used on EWOL propellers for shaft-drive.

Versions of rope cutters for shaft-drives are also available and can be ordered at www.ewoltech.com or www.ewol-propellers.com.



FIG. 38 Sail-Drive rope cutter

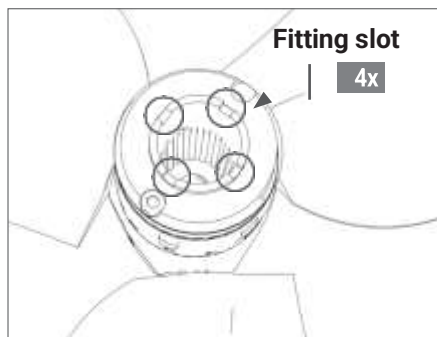

FIG. 39 Fitting slot

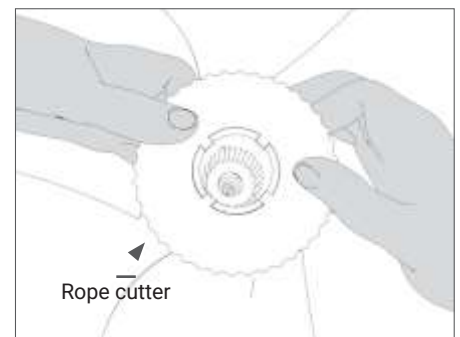

FIG. 40 Sail-Drive rope cutter fitting

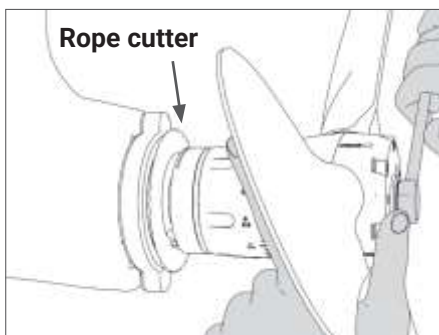

FIG. 41 Rope cutter installed on Sail-Drive

APPLICATION OF ANTIFOULING PAINT

EWOL propellers are supplied with a sandblasted outer surface to improve antifouling paint adhesion.

Launching the boat with an unpainted propeller would result in the growth of marine fouling over time, reducing the efficiency of the propeller.

It is therefore advisable to apply a specific antifouling paint for propellers, which can be ordered at www.ewoltech.com or www.ewol-propellers.com, to prevent fouling and keep the propeller in good working condition. The entire propeller should be painted, except for the galvanic anode and the contact surface between the propeller and the anode.

LUBRICATION

The EWOL propeller is supplied pre-filled with grease, so for the first year of use there is no need to add grease; it is recommended that the propeller be checked for proper lubricant level once a year, in order to preserve the bearings and reduce wear of internal components during operation.

Lubrication must be carried out as follows:

- Unscrew the cap of the grease hole using an Allen key (**Fig. 42**).
- Screw in the grease nipple **G** supplied with the propeller into the hole (**Fig. 43**).
- Fit the nozzle of the grease tube onto the grease nipple (**Fig. 44**).
- Apply EWOL grease that can be ordered on the website www.ewoltech.com or www.ewol-propellers.com (from the USA) using a grease pump (**Fig. 45**), until it leaks from the blade housings or the MPS ring nut.
- When finished, remove the grease nipple and screw the cap back on.

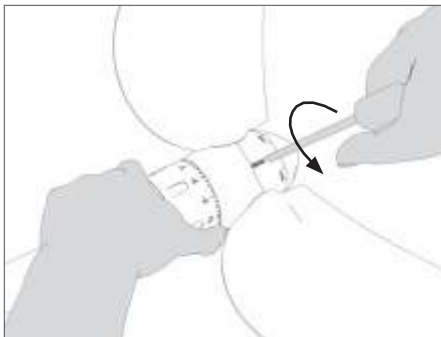

FIG. 42 Unscrewing the grease cap

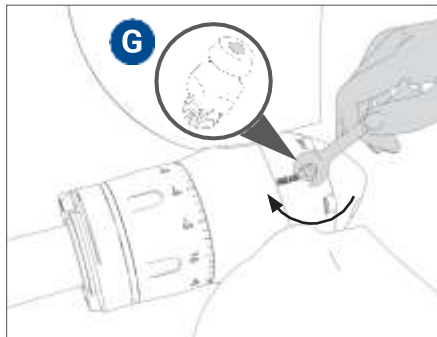

FIG. 43 Screwing on the grease nipple "G"

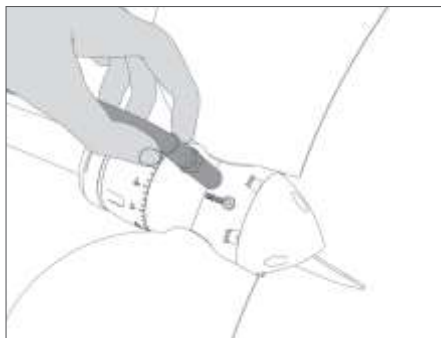

FIG. 44 Grease tube connection

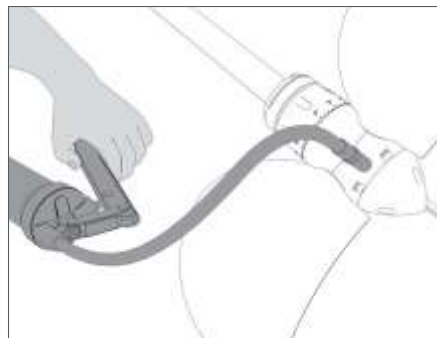

FIG. 45 Grease pumping

MAINTENANCE

In addition to normal maintenance by filling with grease and replacing the sacrificial anode already described in the previous paragraphs, all EWOL propeller models are equipped with sliding bushings and the Orion Sail-Drive version with a shock absorber. These parts are subject to wear, which enables to have completely overhauled propellers even after many years.

For the maintenance intervals, refer to the "Overhauls" chapter of the websites www.ewoltech.com and www.ewol-propellers.com

WARNINGS

- Never work on the propeller while the engine is running.
- Keep clear of the propeller when it is rotating.
- Interventions in the water should be carried out in calm sea conditions to prevent the boat from pitching and posing a danger to the operator.
- Check that the lock nut and the safety bolt are securely tightened before starting the engine.
- If you have locked the propeller shaft, remember to unlock it before restarting the engine.
- Check the free movement of the blades. For properly the movement lock the shaft, then take two blades by hands and rotate the propeller around the shaft clockwise and anti-clockwise, rotation has to be possible without an excessive effort.
- Reverse at low speed to avoid damaging the internal components of the propeller and the gearbox.
- If you have installed a rope cutter, be very careful not to cut yourself when changing pitch, cleaning the propeller, etc. It is strongly recommended that you cover the rope cutter with a cloth rolled up several times in order to avoid serious injuries in case of accidental contact.

EWOL S.r.l.



Milan - Italy

Ph. +39 02 86.46.39.11 - Mobile +39 338 22.93.304

info@ewoltech.com

www.ewoltech.com - www.ewol-propellers.com